

NCM CONCRETE CRUNCHER (NCC)

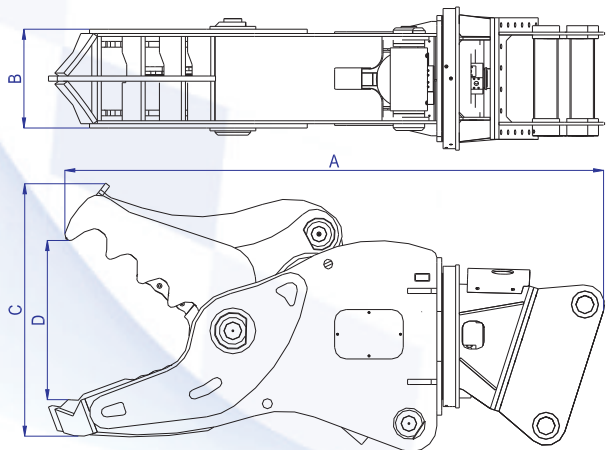
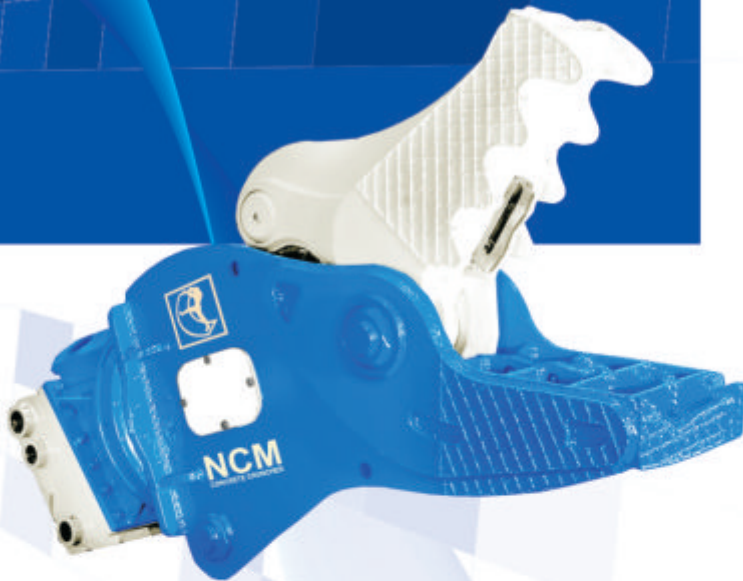

Applications

1. Re-cycling
2. Controlled Demolition
3. Disaster Management
4. Scrap Yards

Technical Specification

Description	Unit	Hydraulic Concrete Cruncher					
		NCC2252	NCC0788	NCC2582	NCC2510	NCC2564	NCC2586
Operating Weight	Kg.	542	1246	1587	2131	2859	5929
Overall Length (A)	mm	1638	2388	2260	2538	2874	3881
Jaw Width (B)	mm	330	410	406	532	495	690
Max. Jaw Height (C)	mm	597	771	1032	1082	1261	1772
Max. Jaw Opening (D)	mm	455	647	719	784	877	1172
Cutting Blades	nos.	02	02	02	02	04	04
Suitable Excavator Class	Tons	4-7	10-16	18-26	26-35	37-50	70-100